

ESTABLISHING A **NEW STANDARD** IN THE COMMERCIAL REFRIGERATION INDUSTRY.

ITS SMALL SIZE MAKES THIS AN IDEAL COOLER FOR PLACES WITH **LIMITED SPACE**.



➤ KEY FEATURES

• PA Refrigeration System

Ensures rapid and effective cabinet cool down and maintains consistent temperature range with minimum energy consumption

• Electronic Temperature Controller

Assures the optimal performance of the cooler, delivering product temperature ideal for consumption.

• High Efficiency Glass Door

Equipped with double panel glass and low-e film to reduce condensation. Door hinge is equipped with a self-closing system to ensure the door closes safely, and returns to original position, without any damages.

• LED Lighting System

Our LED system uses a fraction of the energy of regular fluorescent lights and requires no replacement for up seven years.

• CFC and HFC Free Cyclopentane Foam

Eco-friendly, recyclable and high efficiency cabinet insulation.

ESTABLISHING A **NEW STANDARD** IN THE COMMERCIAL REFRIGERATION INDUSTRY.

PRODUCT VIEWS

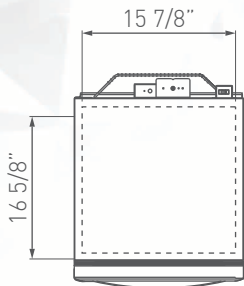

TOP VIEW

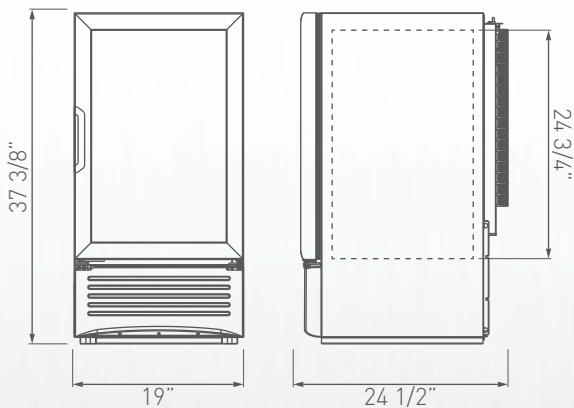

FRONT VIEW

SIDE VIEW

Warranty:

Three year limited warranty on all parts and labor, an additional two year warranty on compressor. (USA and Canada only)

Dimensions rounded up to the nearest inch or millimeter. Specifications subject to change without notice.

Customer Service: 866-363-0079 | WWW.IMBERAFOODSERVICE.COM

TECHNICAL SPECIFICATIONS

Exterior Dimensions	W:	19"	482 mm
	D:	24 1/2"	618 mm
	H:	37 3/8"	950 mm

Interior Dimensions	W:	15 7/8"	404 mm
	D:	16 5/8"	422 mm
	H:	24 3/4"	630 mm

Dimensions w/packaging	W:	26 1/8"	665 mm
	D:	23 3/8"	595 mm
	H:	37 3/8"	950 mm

Shelf Size	W:	15 1/4"	386 mm
	D:	14 5/8"	371 mm

Weight		96.3 Lbs	43.7 kg
Weight w/packaging		100.3 Lbs	45.5 kg

Shelves		3	
----------------	--	---	--

Capacity 20oz.	Flat:	50	
-----------------------	--------------	----	--

REFRIGERATION DATA

Energy Consumption	1.210 kWh/day
---------------------------	---------------

Voltage	115/60
----------------	--------

Horse Power	1/6
--------------------	-----

AMPS	2.1
-------------	-----

LOGISTIC

Trailer Loads	40':	136
	53':	176

Certifications	UL:	✓
	ES:	✓
	UL/EPH:	✓

* Energy consumption based on ANSI/ASHRAE Standard 72-2005.

PA System (Active sides).

Dimensions rounded up to the nearest inch or millimeter. Specifications subject to change without notice.