



MODEL 695D

Single-door Unit Shown



MODEL 695D-S

Single-door Unit Shown

Snack foods have to be hot and moist to be appealing. Cold won't do... Dry won't do. Our humidified model 695 Food Warmers and Displays will keep your snack foods hot and moist with fresh-out-of-the-oven flavor and eye appeal. That means longer holding time with less product loss. And that means more profits for you. Now - isn't that appealing?

FEATURES:

- "Ready to Go" pizza graphic panels on Model 695D
- "Ready to Go" graphic panels on Model 695D-S
- Indicator lights show when water tank is empty/full
- Glass panels and display floor remove for easy cleaning
- Adjustable thermostat
- Temperatures from 80° F to above 150° F
- 2 Door "self serve" option available

MODEL 695D

- Rotating racks accommodate up to a 16" pizza

MODEL 695D-S

- Includes (4) shelves
- Total height of adjustable shelf space: 21"
- Adjustable shelves accommodate up to a 14" pizza
- Additional shelves available (#0018630)

ELECTRICAL DATA:

695D

VOLTS:	120	AMPS:	8.9	WATTS:	1070
---------------	-----	--------------	-----	---------------	------

695D-S

VOLTS:	120	AMPS:	8.5	WATTS:	1020
---------------	-----	--------------	-----	---------------	------

- Best when operated on an individual branch circuit
- 6' power cord length

DIMENSIONS:

- 18½"W × 18½"D × 32"H

SHIPPING INFORMATION:

- **SHIPPING DIMENSIONS:** 26"W × 26"D × 41"H
- **SHIPPING WEIGHT:** 98 lbs.
- **MUST SHIP VIA FREIGHT TRUCK**



IMPORTANT: Read the following safety and operation instructions to avoid injury and to avoid damage to equipment or property.



Plug unit into a properly grounded electrical outlet of the correct voltage, size, and plug configuration for this unit. We recommend usage on an individual branch circuit of at least 15 amps for best results. Failure to do so may result in decreased performance of the warmer.



Exterior surfaces on unit may get hot. Use caution when touching these areas to avoid injury.



Only shatter resistant light bulbs which meet or exceed NSF Standards specifically designed for food holding units must be used. Breakage of bulbs not specially coated could result in personal injury and/or food contamination.



Unplug warmer when not in use.

CLEANING INSTRUCTIONS



Unit is not waterproof. Do not submerge in water. Do not operate if unit has been submerged in water.



Unplug unit from power source, and allow to cool completely before performing any maintenance or cleaning.



Do not steam clean or use excessive water on unit to avoid personal injury or electrical shock.

It is recommended that the interior and exterior surfaces be cleaned daily with a mild soap and damp cloth. Stubborn stains on base of unit and/or shelves may be removed with a non-abrasive cleaner and a damp cloth. Usage of an abrasive cleanser could scratch or damage the finish of your unit.

EQUIPMENT SETUP

FOR UNIT WITH ROTATING TREE - The Carousel Tree and Racks are securely fastened in place for shipping. It is necessary that the Carousel Collar (located at the center of the Ceiling Chamber) and the four rotating Racks be released prior to operation.

OPERATION:

This warmer is designed to maintain food product at or above the optimum temperature. It is not designed or intended to heat up or cook food to the serving temperature. Product is to be prepared to a temperature of above 160° F before placing in the warmer.

OPERATING INSTRUCTIONS

1. Plug unit in, and turn the Power Switch located at the control panel to “ON”.
2. Set the Temperature Selector to the desired temperature.
3. Fill the Water Reservoir. See *Water Reservoir*

Allow 30 minutes to preheat a full reservoir of water. The elements automatically energize as needed to maintain the desired setting.

The reservoir capacity permits uninterrupted operation for approximately 8-12 hours depending upon settings and how frequently the door is opened.

The green lamp is designed to prevent overfilling of the water reservoir. Its only function is to indicate when the reservoir is full and to stop adding water. As the water level recedes, the green lamp will deactivate.

When the red indicator light activates, it is signaling that the water level is low, and water should be added to the unit immediately.

WATER RESERVOIR

On initial start-up, add distilled water to the reservoir until the green indicator light activates signaling that the reservoir is full. We recommend using distilled water only to preserve the life of the electrical and mechanical components.

If you do not have distilled water available for the initial operation of the unit, regular tap water may be substituted. However, continued use of tap water over a period of time will result in diminishing efficiency and eventual failure of the humidity control components.

The reservoir fill is located on top of the cabinet. Slide the cover open, and fill the reservoir with distilled water. It is important to reposition the cover after filling the reservoir to maintain a sanitary environment within.



NOTE: Reservoir capacity on initial fill is 3 quarts 8 ounces maximum. Refill capacity at the time the red indicator lamp activates is 2 quarts maximum.

DRAINING WATER RESERVOIR: As a safety precaution, it is recommended that the 695 Display Warmer water reservoir be drained prior to moving the unit. This is to prevent water from spilling into the food compartment or onto electrical components.

MAINTENANCE:

TO REPLACE DISPLAY LIGHT



Only shatter resistant light bulbs which meet or exceed NSF Standards specifically designed for food holding units must be used. Breakage of bulbs not specially coated could result in personal injury and/or food contamination.

Disconnect the power supply cord, and wait until unit has completely cooled. Unscrew light, and replace with a new specially coated bulb of the same style and wattage.

REVERSIBLE DOOR:

The Access Door is designed for easy conversion to open right or left. Survey the selected operating area to determine if conversion is necessary.

TO CONVERT DOOR:

1. **TURN UNIT OFF:** DO NOT tip unit on its back or sides. Water will escape from the reservoir causing electrical short or possible shock.
2. **REMOVE DOOR:** Slide the front of the Food Warmer toward the edge of the counter or table top until the lower Hinge Pin is accessible by screwdriver. While supporting the door, remove upper and lower Hinge Pins and Nylon Spacers.
3. **REVERSE HINGES:** Using a 3/32" Allen Wrench, remove the (4) Button Screws located on the right and left columns. Move the Hinges to the opposite column, and reassemble.
4. **REPLACE DOOR:** Rotate the door 180 degrees, insert Spacers and Hinge Pins. NOTE: The Nylon Spacers must be reinserted between the door and hinges.

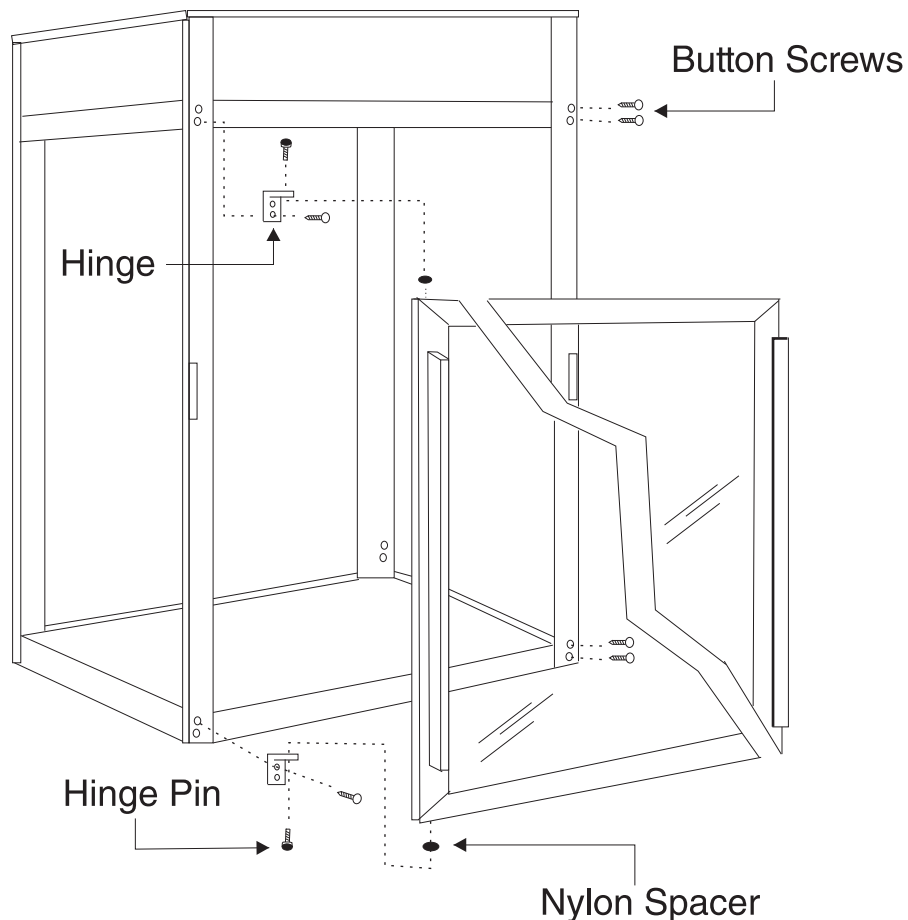

PARTS LIST:**MODEL 695D**

ITEM #	PART #	DESCRIPTION
1	0016428	10-32 X 3/8 BRASS THUMB SCREW
2	0017201	COVER PLATE
3	0017435-16	WIRE RACK 16" PIZZA
4	0017402	PIZZA TREE WELDMENT
5	0017379	HIGH LIMIT THERMOSTAT
6	I013759	READY TO GO PIZZA SIDE PANEL DECAL
*	I013758	READY TO GO SIDE PANEL DECAL
7	00175	NUT
8	0017593	WASHER SPACER
9	0017351SK	LIQUID LEVEL SWITCH SERVICE KIT
10	0017350	HUMIDITY TANK
11	0017270	CAROUSEL BUSHING (.40 DEPTH)
12	0018630	WIRE RACK
13	0022309	BLOWER MOTOR (FOR 695 SERIES: SEE REPAIR INSTRUCTIONS TAB BELOW)
14	0018631	BRACKET
15	0018632	END COVER
16	0021012	BLOWER MOTOR W/ METAL SHROUD (SEE REPAIR INSTRUCTIONS TAB BELOW)
17	0016428	10-32 X 3/8 BRASS THUMB SCREW
18	0016418	LIGHT SOCKET ASSY
19	0017265	TUFFSKIN INCANDESCENT LAMP
20	0020943	ADJUSTABLE DOOR CLIP
21	0018656	3/16" CLEAR TEMPERED GLASS
22	00448	POWER CORD - 15A
23	0017436	NYLON GLIDE
24	0021070	BOTTOM PAN WELDMENT
25	0020935	DOOR ASSY
26	0016024	STRAIN RELIEF
27	0020942	MAGNET ASSY
28	0017306	DOOR SWITCH
29	0017596SK	GEAR MOTOR SERVICE KIT (Incl. 0017331 fan blade)
30	0017331	FAN BLADE (DRIVE & BLOWER MOTOR)
31	0017271	DOOR HINGE
32	0018629	RACK HOLDER
33	0019577	800W, 115V HEATING ELEMENT
34	0017354	HORIZONTAL DRUM THERMOMETER
35	0017274	THERMOSTAT KNOB
36	009092	RED PILOT LIGHT
37	009093	GREEN PILOT LIGHT
38	0016119	ON/OFF SWITCH
39	I013748	CONTROL PANEL DECAL
40	0017249	AIR THERMOSTAT (95-215 DEG)
*	009126	4" FOOT RETRO FIT KIT

Model 695D Exploded View

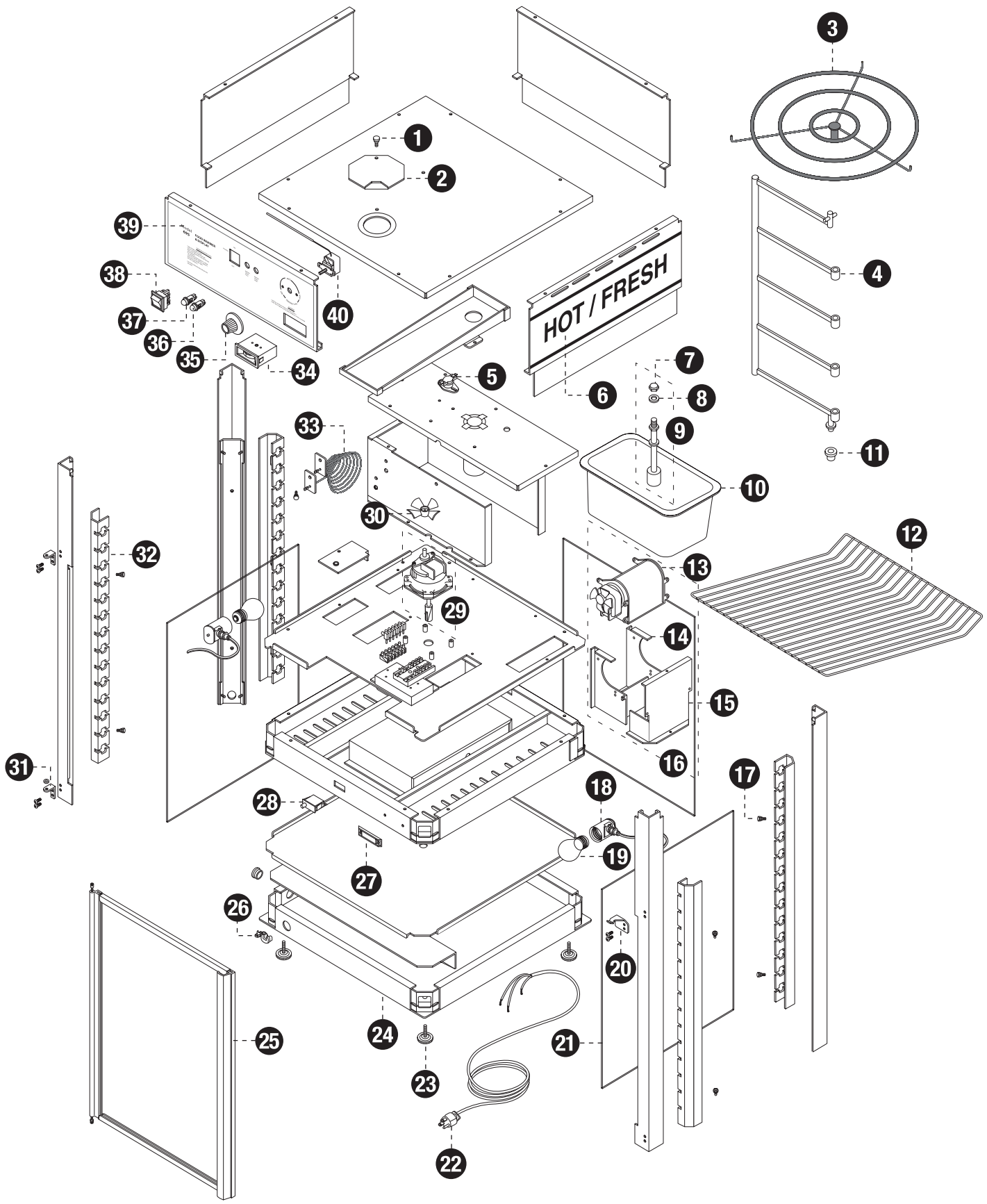

Model 695D Wiring Diagram

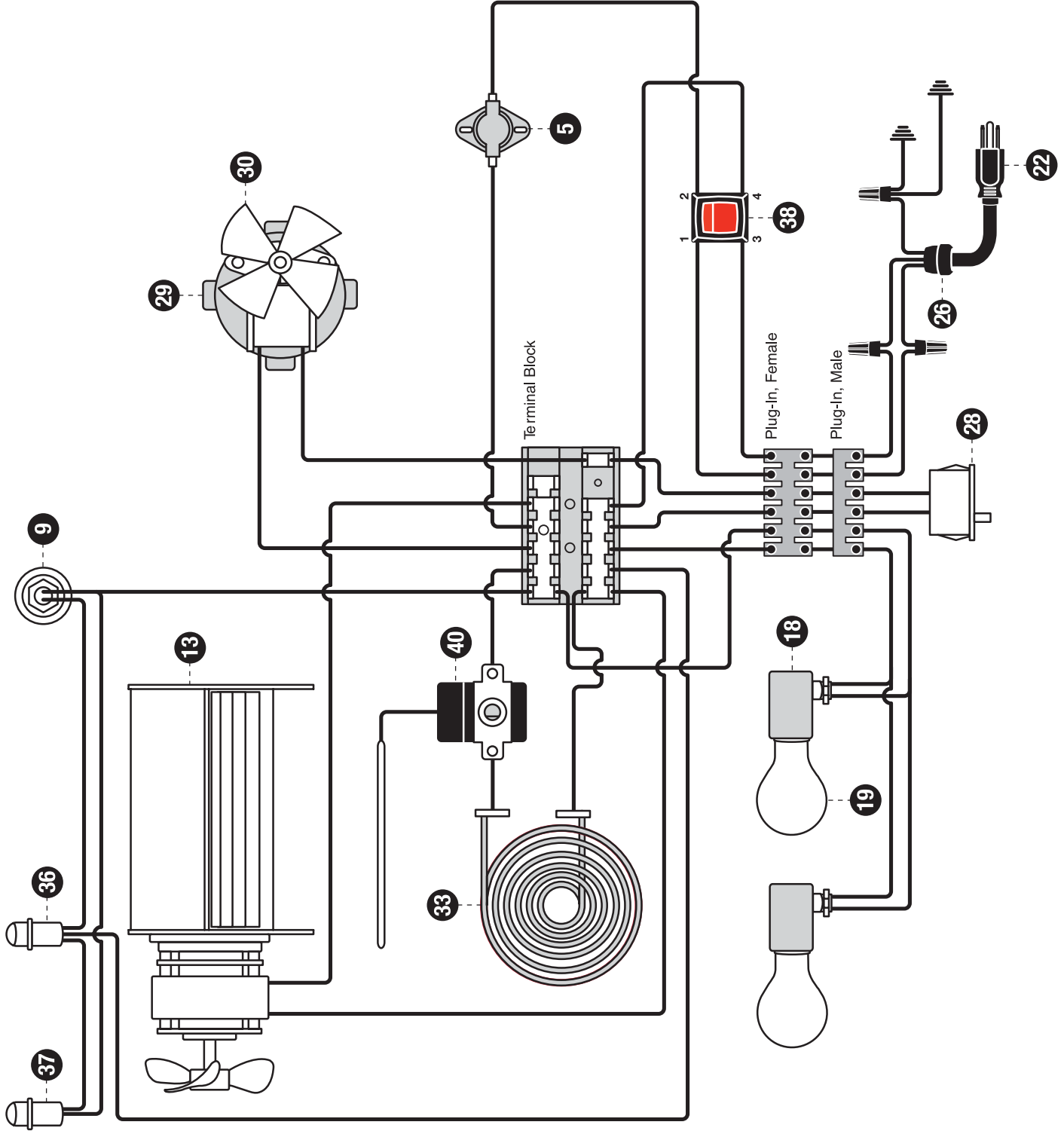

1 YEAR REPLACEMENT/EXCHANGE

Wisco Industries, Inc. warrants its equipment against defects in materials and workmanship subject to the following conditions:

Should any product fail to function in its intended manner under normal use within the limits defined in this warranty, Wisco Industries will determine if the item is to be repaired or replaced by Wisco Industries. Failure to follow authorizing instructions may void any claim and/or warranty.

* Contact Wisco Industries for repair/replacement by calling (608) 835-3106 or toll free (800) 999-4726.

You can also email us at: contact@wiscoind.com

* An authorizing RMA# must be obtained through Wisco Industries BEFORE any warranty issues can be resolved. Failure to do so in advance may void the warranty/claim resulting in Wisco Industries not being responsible for any incurred expenses and/or charges.

* At time of call Wisco Industries will assist you in:

- getting your unit replaced/exchanged
- and/or obtaining repair parts
- and/or authorizing a service agent

This warranty covers products shipped into the 48 contiguous United States, Hawaii, metropolitan areas of Alaska and Canada only. Warranty for international or areas not listed above will consist of replacement of parts only. There will be no labor coverage and parts must be shipped to an address within the 48 contiguous United States, Hawaii, metropolitan areas of Alaska and Canada only.

Time Period

One year from date of shipment from our manufacturing facility. Parts replaced under this warranty are warranted for the un-expired portion of the original product warranty only.

Exclusions

The following conditions are not covered by warranty:

- Equipment failure relating to improper installation and improper utility connection or supply.
- Equipment that has not been properly maintained or damage from improper cleaning and/or water damage to controls.
- Equipment that has not been used for its intended purpose or has been subject to misuse or misapplication, neglect, abuse, accident, alteration, negligence, damage during subsequent transit, delivery or installation, fire, flood, riot or act of god.
- Equipment that has the model number or serial number removed or altered.

WISCO INDUSTRIES, INC. DISCLAIMS AND EXCLUDES ANY AND ALL OTHER EXPRESS OR IMPLIED WARRANTIES, INCLUDING WITHOUT LIMITATION, ANY AND ALL WARRANTIES OF MERCHANTABILITY OR FITNESS FOR A PARTICULAR PURPOSE. Buyer agrees that its SOLE AND EXCLUSIVE REMEDY against Wisco and Wisco's SOLE AND EXCLUSIVE LIABILITY arising out of any defect or nonconformity in the product shall be replacement/exchange of such nonconforming countertop food service equipment at Wisco's expense. No countertop food service equipment shall be returned without Wisco's consent. IT IS AGREED THAT WISCO'S MAXIMUM LIABILITY SHALL NOT IN ANY CASE EXCEED THE SALE PRICE FOR THE COUNTERTOP EQUIPMENT CLAIMED TO BE DEFECTIVE OR NONCONFORMING.

Without limiting the generality of the foregoing, SUCH WARRANTIES DO NOT COVER: Glass, plastic enclosures/panels, door assemblies, hardware, light bulbs & wire pizza oven heating elements.

SHIPPING DAMAGE

If the outside packaging of your order is visibly dented, crushed, torn or otherwise significantly damaged, or if you move the carton and you hear broken glass, please reject the shipment while driver is still with you if possible. Please call us at (800) 999-4726 or email contact@wiscoind.com to notify us of the issue. We will confirm the damage with the carrier and re-ship your order immediately.

RETURN POLICY

You may return any unused, undamaged items within 30 days of receipt. We will issue a refund in the form of your original payment, less a 20% restock fee. All returns must be received in resalable condition. Wisco Industries will not accept a return with shipping damage. Wisco Industries will not reimburse any shipping and handling fees.

If you would like to return an item please call us at (608) 835-3106 or toll free at (800) 999-4726 and ask for our Food Service Equipment Division or you may send an email to us at: contact@wiscoind.com. You will be given a return # and return instructions. We cannot accept returns without a return #. Please be sure to include a copy of the packing list with the return.